

89-98 Suzuki Sidekick, X-90, or Geo Tracker Budget 2" Lift Kits.

Instructions Include: SKU# KSP-BBLK Basic Kit

SKU# KSP-CBLK Basic Kit W/Shocks

SKU# SPC-81250 Camber Alignment Bolts

Installation Instructions



Camber Alignment Bolts



Rear Shock Absorbers

CAUTION: Safety glasses should be worn at all times when working with vehicles and related tools and equipment.



Suggested Tools:

- Twin Post Lift & Hoist Jack Stand
- Floor Jack
- Slip Joint Pliers
- 4 Jack Stands (If using floor jack only)
- Lug Wrench, 19 mm
- 1/2" Impact Wrench (Optional)
- Sockets: 10,12,14,17,19 mm & 1/2"
- Ratchet
- 16 mm & 1/2" Combination Wrench
- 2-14 mm Combination Wrenches
- 5/16 Drill Bit (Supplied in the Kit)
- Electric Hand Drill
- Brass Hammer
- Ball Peen Hammer
- 1/8 Inch Tapered Diameter Punch
- Bench Vice
- Penetrating Oil
- Diagonal Cutting Pliers
- Die Grinder (Air or Electric)
- 1/2" Carbide Deburring Bit

Front Suspension Lift

Front Suspension Parts

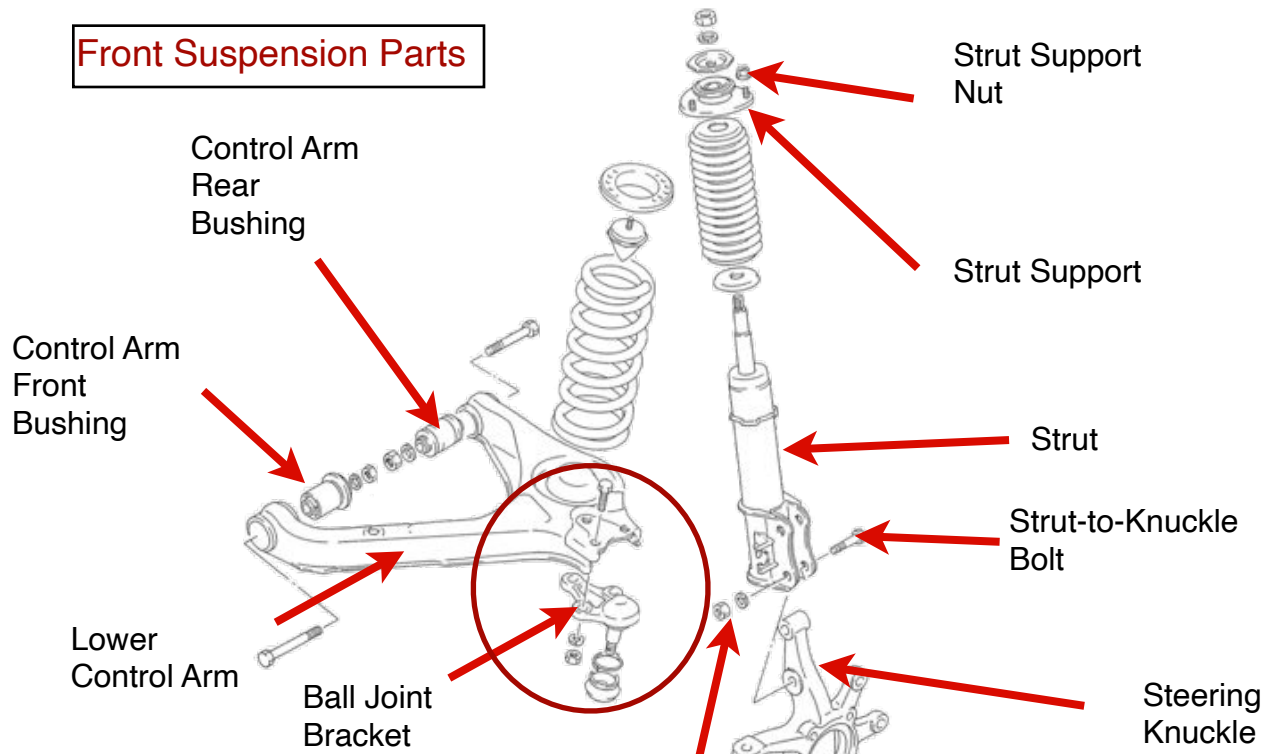

Figure A

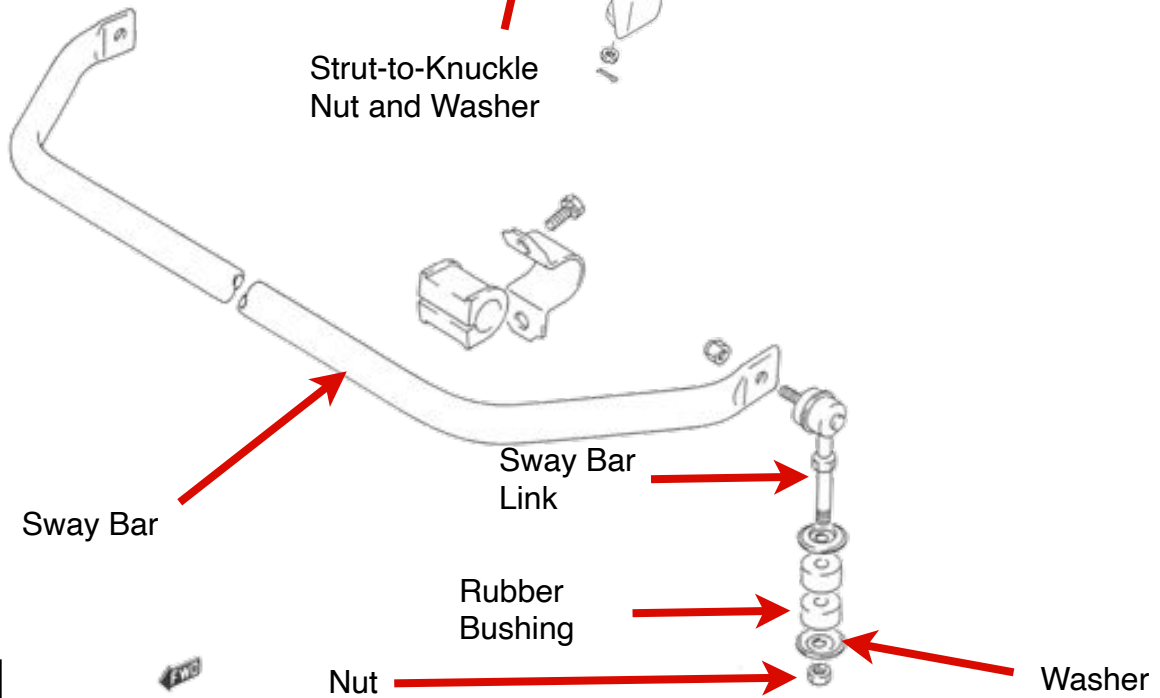

Figure B



Step 1

Safely raise and support the vehicle on a twin post lift supported by the frame. If there is no lift available, a floor jack and 4 jack stands are a good alternative. This job could also be done with a floor jack and only 2 jack stands if that is all you have.



Step 2

Remove the left front wheel using a 19 mm socket or lug wrench.



Step 3

Pull the hood release inside the glove box.



Step 4

Release the hood safety latch and open the hood.





Step 5

Place a floor jack (or hoist jack stand) under the lower control arm and lift up slightly.

Note: Do not lift so much that the vehicle lifts off the lift (or Jack Stand).



Step 6

Remove the (3) upper strut mount bolts using a 14 mm socket.(See Figure A)



Step 7

Guide the top of the strut down as shown.

Note: It may be necessary to push down on the strut support to get the strut in this position.



Step 8

Remove the brake line attaching clip located on the side of the strut, using slip joint pliers.



Step 9

Detach the flexible brake line from the support bracket.



Step 10

While holding the upper strut-to-knuckle bolt with a box end wrench remove the nut using a 17 mm socket.



Step 11

Begin removing the upper strut-to-knuckle bolt by tapping it out with a brass hammer.

Caution: Do not damage the threads of the bolt by pounding. This bolt will be reused.



Step 12

Finish removing the upper strut-to-knuckle bolt by tapping it out with a punch.



Scan to see VIDEO on how to test struts and shocks.

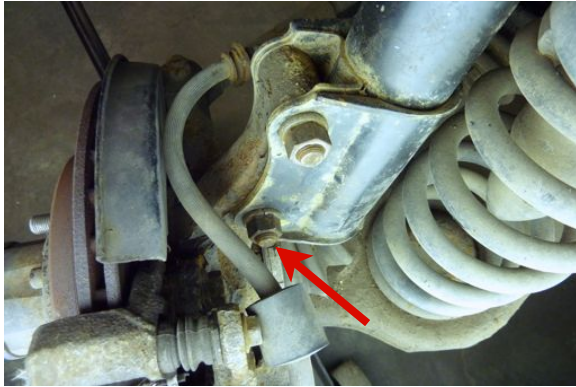

Step 13

Repeat **Steps 10 to 12** on the lower strut-to-knuckle bolt.



Step 14

Remove the strut.

Note: Click [HERE](#) to see a video on how to test a strut to see if it is reusable.

Note: If the strut needs replacing click [HERE](#) to see what is available at Low Range Off-Road.



Step 15

Disconnect the sway bar link from the lower control arm by removing the nut using a 14 mm socket. Remove the washer and bushing as well.



Step 16

Loosen the front lower control arm bushing bolt by holding it with a 14 mm combination wrench and turning the nut with a 14 mm socket.



If the vehicle you are working with has the ball joint INTEGRAL (in one unit) with the lower control arm as shown in Figure C, continue to the next step. If the vehicle you are working with has the ball joint BOLTED to the lower control arm as shown in Figure D, skip to Step 19.

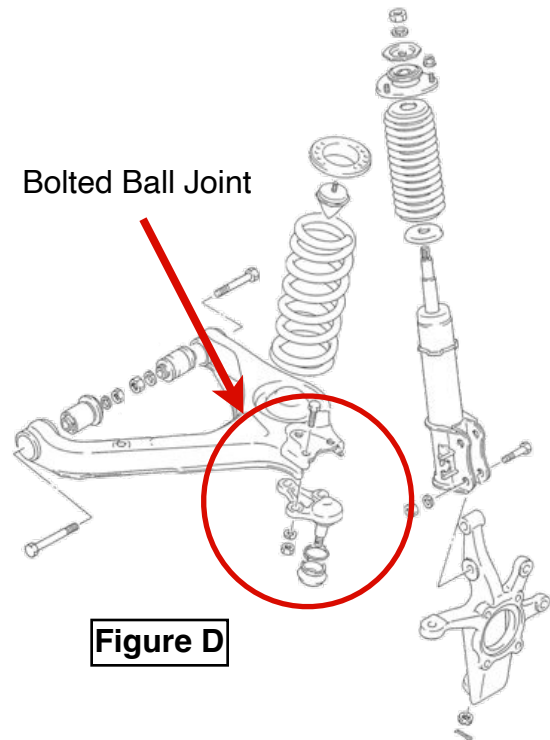
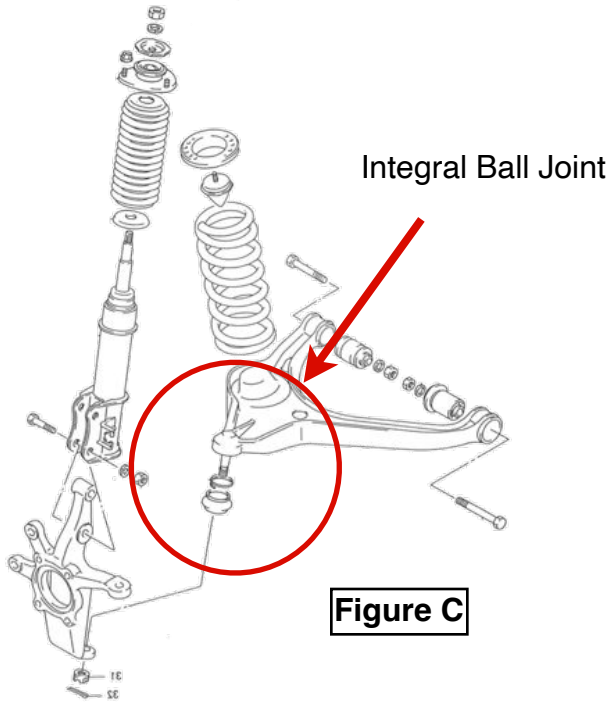

Step 17

Disconnect the drive axle at the inner end by removing the three bolts using two 14 mm combination wrenches.

Step 18

Once you have the drive axle unbolted skip to **Step 21**.



Procedure to follow when the ball joint is bolted to the lower control arm



Step 19

With the lower control arm supported, remove the (3) ball joint nuts & lock washers by holding the bolt from the top with a 17 mm box end wrench and removing the nut with a 17 mm socket.

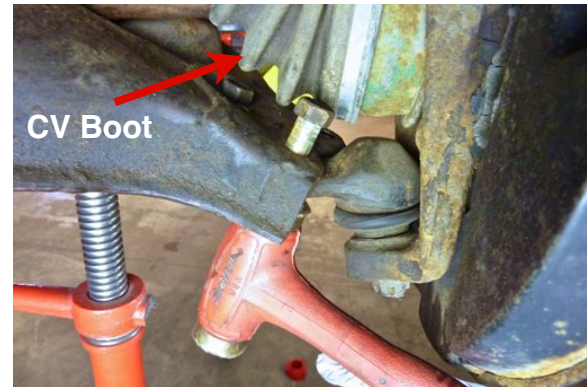

Step 19 Continued

After removing the nuts and lock washers, tap the bolts upward with a brass hammer, one at a time, to remove the bolt.

Caution: Be careful to not damage the CV Boot. It may be necessary to shift the steering knuckle side to side or up and down to allow the bolts to be removed.



Step 19 Continued

After the (3) bolts are removed, pull outward on the steering knuckle until the ball joint bracket clears the lower control arm.



Step 20

While lifting out on the steering knuckle, lower the control arm, allowing the ball joint bracket to be positioned above the control arm as shown here.



Step 21

Lower the control arm with the floor jack (or hoist jack stand) which will decompress the coil spring.



Step 22

Lift out the coil spring; bottom first and then the top.



Step 23

Position the supplied spacer on the upper spring mount.

Note: The original upper spring seat is to remain in place. Do not remove it.



Step 24

Tap the spacer upward with a hammer until it is seated against the original spring seat.





Step 25

Reinstall the coil spring; top first and then the bottom.

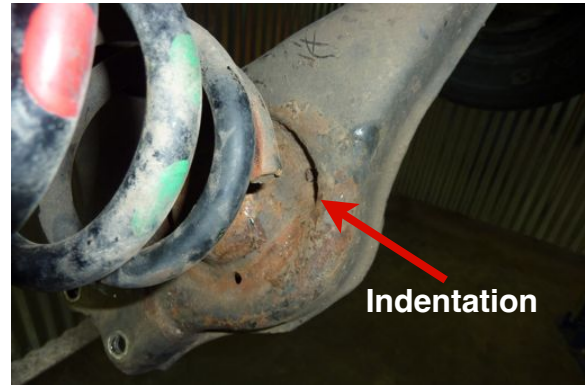

Step 26

Rotate the coil spring until the bottom is seated properly in the lower control arm.

Note: The lower control arm has an indentation that matches the shape of the bottom of the coil spring.



Step 27

Using the floor jack (or hoist jack stand) raise the lower control up into position, compressing the coil spring.

Note: If you are working with an Integral ball joint skip to Step 31.



Step 28

As the lower control is raised, reposition the lower ball joint back into its original position on the bottom of the control arm.





Step 29

Reconnect the lower ball joint to the lower control arm by installing the (3) bolts.

Note: It may be necessary to move the steering knuckle in and out or up and down to be able to install these bolts. Be careful not to damage the CV boot.



Step 30

Install the ball joint nuts and while holding the bolt with a combination wrench, tighten the bolts with a socket. 50 to 75 ft. lbs.



Step 31

Raise the lower control arm until the vehicle is almost raised off the lift (or jack stand).



Step 32

Tighten the front lower control arm bushing nut to specification. 50 to 75 ft. lbs.



Step 33

Tighten the rear lower control arm bushing nut to specification. 65 to 100 ft. lbs.



Step 34

Reinstall the sway bar link in the lower control arm.



Step 35

Install the rubber bushing, washer and nut. Tighten the nut to specification. 25 to 30 ft. lbs. (See Figure B)



Step 36

If the vehicle you are working with has the integral ball joint, reconnect the drive axle and tighten the (3) bolts. 29 to 43 ft. lbs.

Upper Strut Support Modification



Step 37

Position the upper strut support in a vice as shown.

Note: The vice jaws should be about 3/4 of inch apart, just enough room for the head of the stud to pass through.

Step 38

Thread a nut on the stud so the top of the stud and the top of the nut are flush. This is done to reduce mushrooming of the bolt, making it more difficult to remove.



Step 39

Pound on the nut and stud with a ball peen hammer driving the stud out of the bottom of the upper strut support.

Step 40

When the stud moves down to where the nut touches the upper strut, thread the nut upward and continue pounding.



Step 40 Continued

This shows the stud nearly out.



Step 41

Remove the nut and continue driving the stud with an 1/8 inch diameter punch.



Step 42

Repeat **Steps 37 to 41** on the other two studs.



Step 43

Once the (3) studs are removed, drill out each hole with the 5/16 drill bit that is provided in the kit.

Note: This is to accommodate the slightly larger diameter fasteners that come with the lift kit.



Step 44

Reposition the strut back in the vehicle.



Step 45

Install the bottom strut-to-knuckle bolt and nut. Do not tighten yet.

Tech Tip

When this lift kit is installed the front wheel camber shifts in a positive direction (top of the tire moves outward). This shift not only affects camber but it also affects the toe. To address the camber wheel alignment concern, we have two recommendations. The best solution is to install the Camber Alignment Bolts SKU# KSP-CB. If this is your choice begin at the next step. Another less expensive option is to elongate the upper strut-to-knuckle mounting holes in the strut. For these instructions skip ahead to **Step 51 "Strut modification"**.

Camber Alignment Bolt Installation

If you are NOT installing the (SKU# SPC-81250) skip to Step 51.

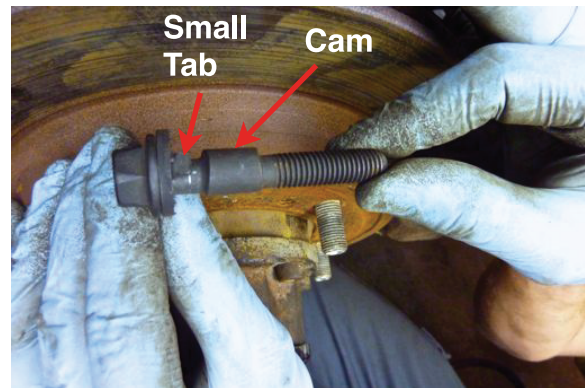
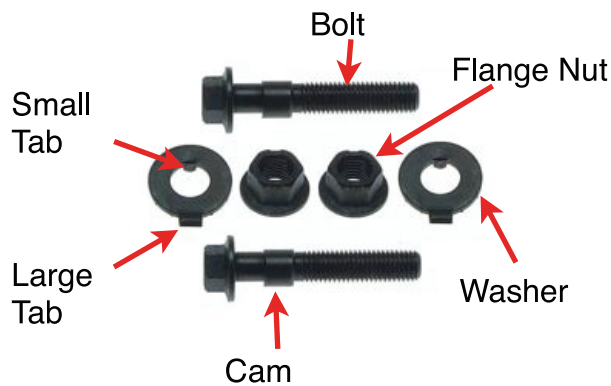

Tech Tip

This picture shows the parts of the camber alignment bolt **SKU# SPC-81250**.

Note: We recommend using these bolts to allow for a more accurate camber adjustment.

Step 46

To install the camber bolt begin by installing the washer on the bolt with the small tab toward you. Position the bolt so that the cam is also toward you.

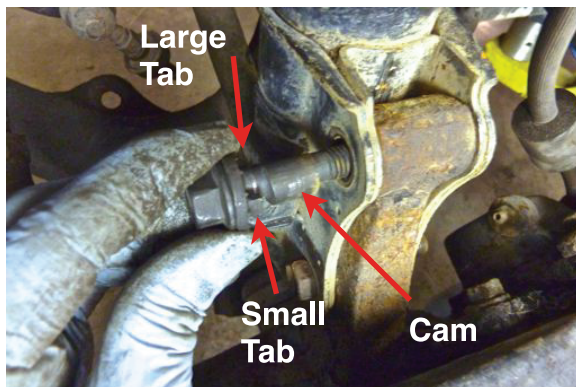

Note:
Install large tab in direction of desired camber change: out for positive and in for negative.

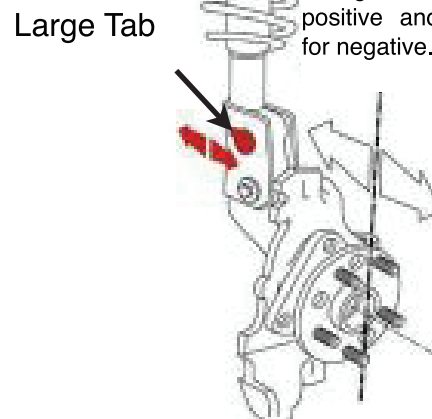

Step 47

Insert the camber alignment bolt with the cam **OUT** toward the wheel, the washer small tab **OUT** toward the wheel and the large tab **IN** toward the engine. (See Figure E)

Figure E



Step 48

Install the camber alignment flange nut. Snug the nut, but do not tighten all the way yet. The bolt needs to be loose enough to turn with a wrench.

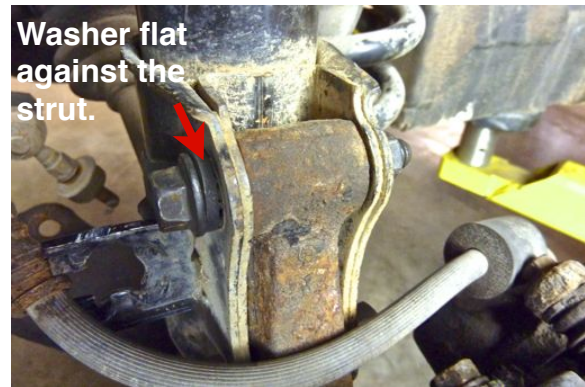

Step 48 Continued

Be sure the washer is flat against the strut and the small tab is out of sight, inside the bolt hole of the strut.

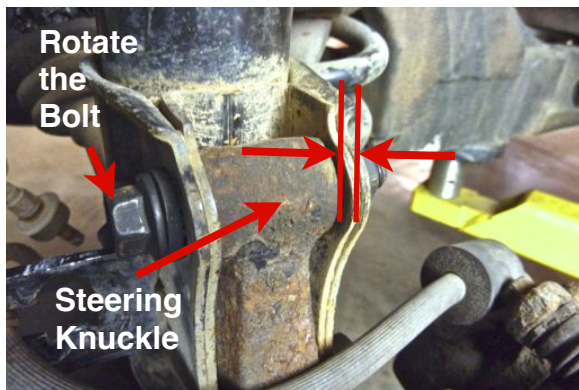

Step 49

Rotate the bolt such that the steering knuckle is as far inward (toward the engine) as possible.

Note: This setting places camber pretty close to factory specification. However, you will still need to have this vehicle professionally aligned when this installation is complete.



Step 50

Torque the top strut-to-knuckle nut to 55 ft. lbs. and the bottom nut to 58 to 75 ft. lbs.

Skip Ahead to Step 57



Strut Modification

Reinstalling the strut WITHOUT the Camber Alignment Bolts.

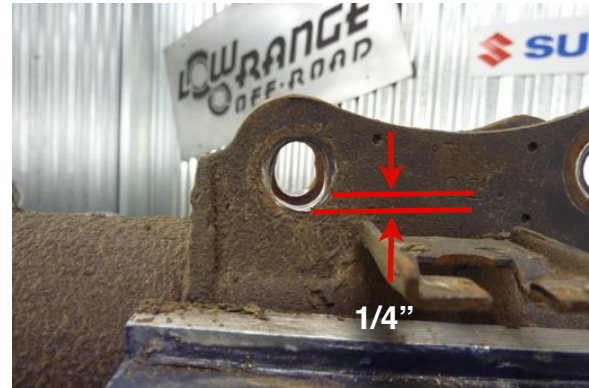

Step 51

When this vehicle is lifted, the camber angles will be affected. The camber will go more positive or out at the top of the tire. To compensate for this, you should slot (or elongate) the top strut-to-knuckle holes as shown.

Note: We used a die grinder with a 1/2" cylindrical carbide deburring tool.

Step 52

Holes properly elongated. They should be elongated about 1/4 of an inch toward the strut (or engine).

Note: Do not elongate the bottom hole.

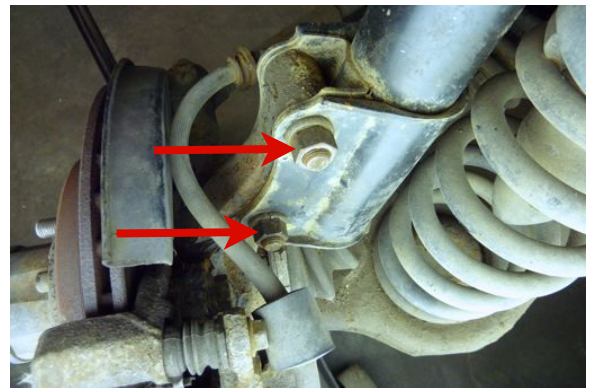

Step 53

Reinstall the strut back in the vehicle.

Step 54

Install both original strut-to-knuckle bolts, lock washers and nuts. But do not tighten them yet.

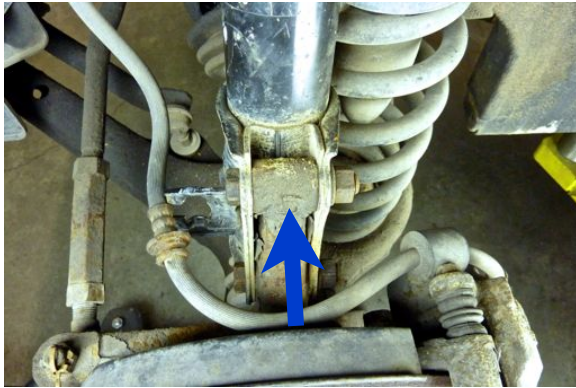

Step 55

Push the steering knuckle as far inward (toward the engine) as possible.



Step 56

While holding the knuckle inward, tighten the strut-to-knuckle bolts (upper and lower). 58-75 ft. lbs.

Connecting the Upper Strut



Step 57

Position the spacer on top the strut as shown.



Step 58

Guide the strut support into the strut tower as shown.

Note: If this is a gas strut it will go up on its own. If not you will need to push the strut support up into position



Step 59

Twist the strut support and spacer so that the holes align as shown.



Step 60

Install the supplied longer (3) bolts in the holes, from the bottom up and install the supplied nylock nuts.



Step 61

While holding the bolt with a 1/2" combination wrench from below, torque the nuts using 1/2" socket. (14 to 22 ft. lbs.)

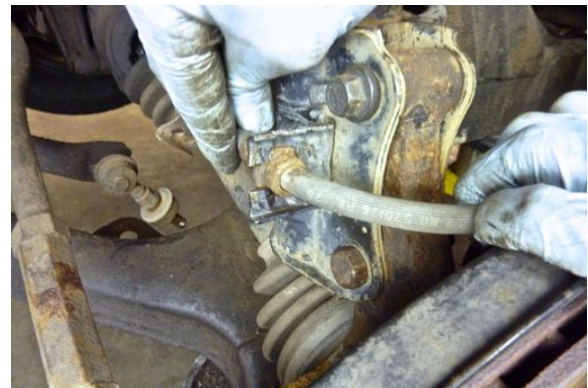

Step 62

Reposition the brake line in the bracket.



Step 63

Install the clip by tapping it into place with a hammer.



Step 64

Reinstall the wheel assembly and lug nuts. Torque to 55 ft. lbs.

Step 65

Repeat all previously performed steps on the passenger side front wheel of the vehicle with one possible exception.

Exception: If the vehicle you are working with has the lower ball joint integral (all in one piece) with the lower control arm (See **Figure C**), you will need to disconnect the drive axle from the differential by prying it loose as shown in the next step. This will free the lower control arm enough to allow the coil spring to be removed.



Step 65 Continued

This picture shows how to disconnect the passenger side drive axle at the differential. This normally does not require much force.

Note: Be sure to place a pan under the differential in case oil comes out when the drive axle is disconnected.

Rear Suspension Lift

Rear Suspension Parts

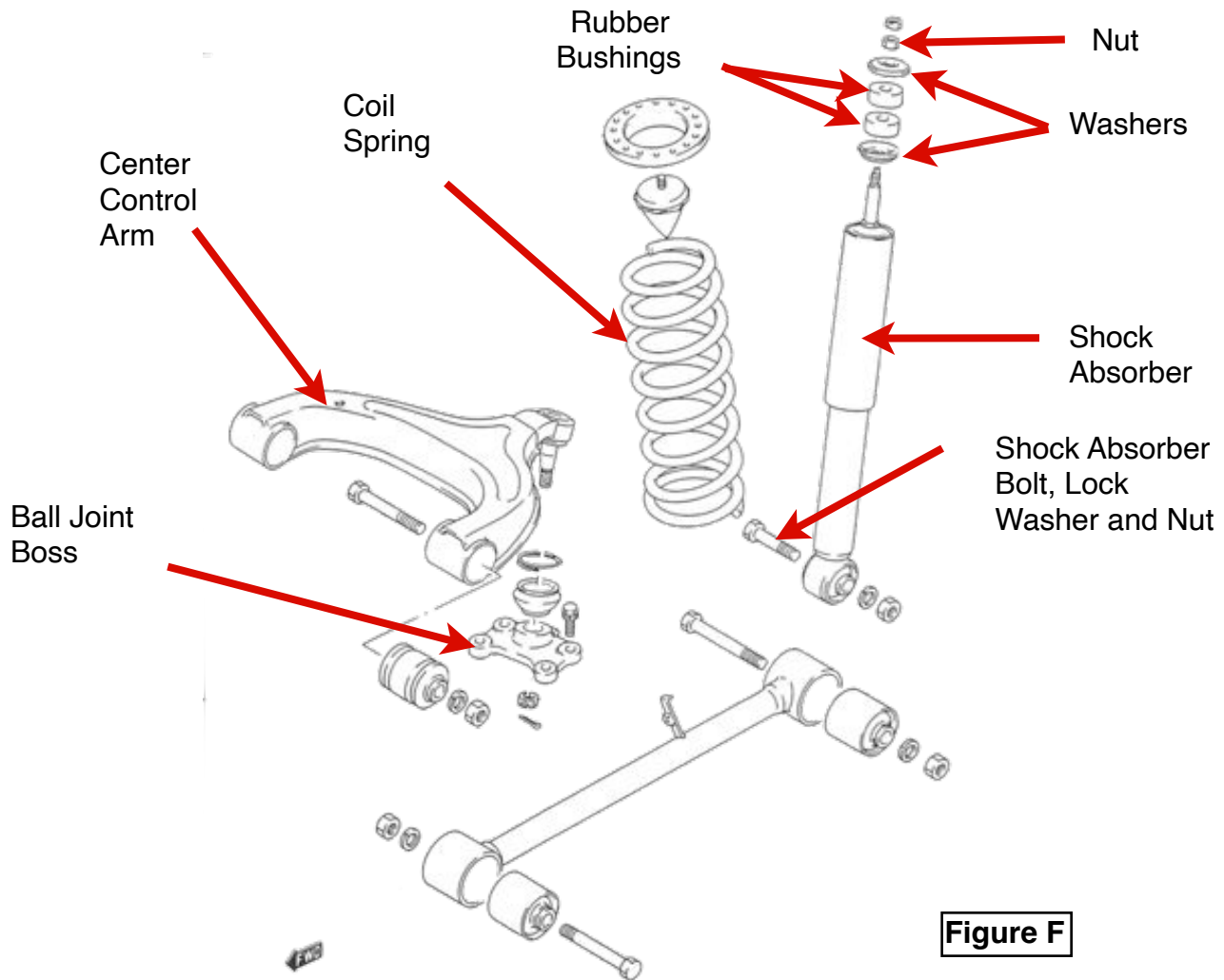

Figure F





Step 66

Lift and support the rear of the vehicle if not done previously.

Note: The vehicle should be supported on the frame just ahead of the rear wheel.



Step 68

Support the rear axle assembly with a floor jack (or under hoist jack stand) as shown.

Caution: Failure to support the rear axle assembly could allow the entire right side of the rear axle to drop resulting in possible personal injury and or vehicle component damage.



Step 67

Remove the (2) rear wheels using a 19 mm socket.



Step 69

Disconnect the right rear shock absorber at the bottom end by holding the nut with a 17 mm combination wrench and a turning the bolt with a 17 mm socket. Then remove the bolt.

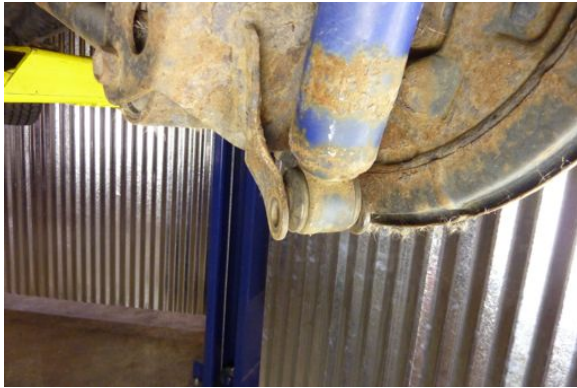

Step 70

Disconnect the shock absorber by slightly lowering the rear axle assembly.

Note: It may be necessary to pry the shock absorber out of the bracket with a large screw driver or pry bar.



Step 71

Disconnect the upper end of the shock absorber by holding the shock absorber with a 16 mm open end wrench and turning the nut with a 14 mm box end wrench (or ratcheting box end wrench).

Note 1: It may be helpful to spray the threads with a good penetrating oil.

Note 2: Some OEM shocks will have two nuts at the top of the shock (See Figure G). In these cases, hold the bottom nut with one 14 mm wrench and loosen the top nut with another 14 mm wrench.



Step 72

Remove the top shock absorber bushing and washer.

Note: Notice our upper shock absorber stud broke before the nut unthreaded on our shock. This is not uncommon when parts are old and rusty. If this happens to you, you will need to replace the shock absorber.

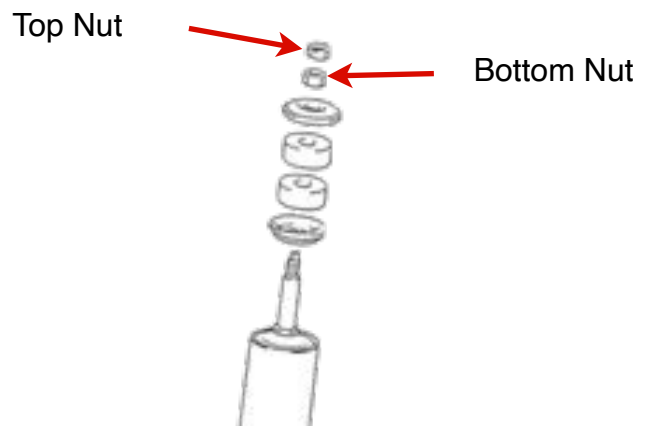

Figure G



Step 73

Disconnect the park brake cable bracket using a 10 mm socket or box end wrench.



Step 74

Slowly lower the rear axle assembly until the coil spring becomes loose.

Caution: Do not lower the rear axle any lower than absolutely necessary. As you lower the rear axle assembly, observe the flexible brake lines and emergency brake cables to insure they are not stretched beyond their limits. You may need to slightly bend brake line brackets to gain a little more slack in these hoses.

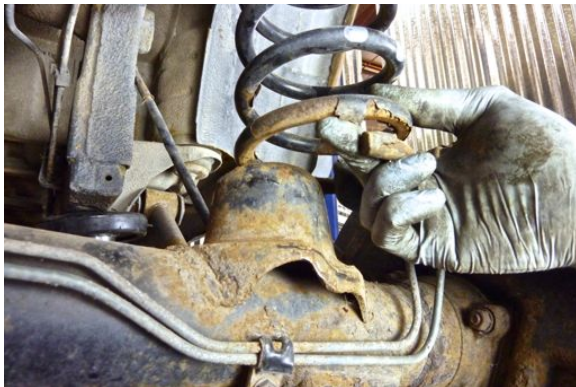

Step 75

Remove the coil spring by disconnecting the bottom first; and then the top.

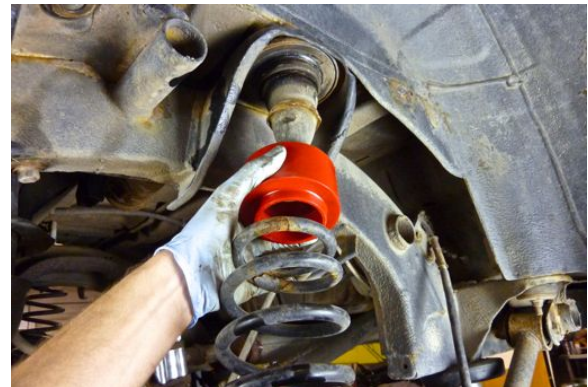

Step 76

Install the supplied spacer on top of the coil spring (smaller end of the spring goes upward) and reinstall the spring, top first . . .





Step 77

And then the bottom.

Caution: You may have to lower the rear axle assembly a bit more. Again, be careful. Do not over stretch the flexible brake lines and emergency brake cables.

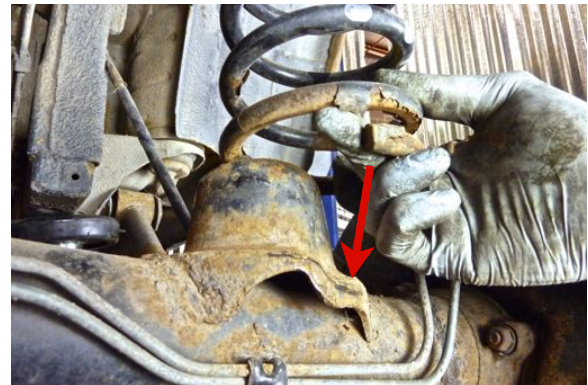

Step 77 Continued

Be sure to rotate the spring until the bottom coil fits properly in the spring seat.

Shock Absorber Installation

(If you are not installing new shock absorbers, skip to Step 80)

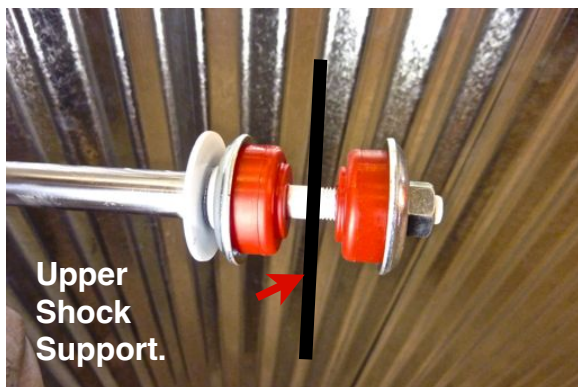

Tech Tip

This picture shows the proper positioning of the upper shock absorber mounting parts.



Step 78

Insert the bushing sleeve in the lower end of the shock absorber as shown.

Note: There 2 sleeves supplied with the shock. We used the longer sleeve which worked well for us.

Skip Step 79 if there is not band.



Step 79

Hold the shock absorber away from you and cut the band.

Note: The shock absorber will move slowly, on its own, to full extension.

Step 80

Place a washer and nylon bushing on top of the shock absorber as shown and insert the shock in the upper shock support.

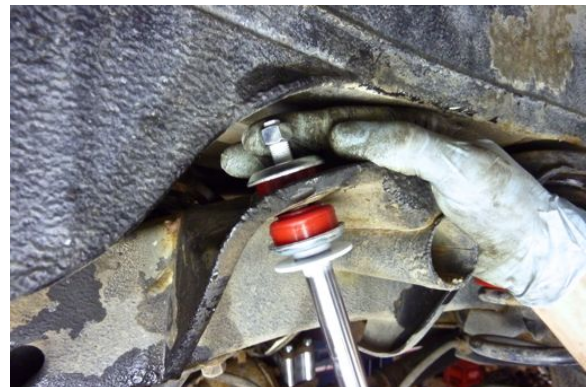

Step 81

Install the second nylon bushing and washer as shown.

Note: Insure that the bushings are positioned as shown in the Tech Tip before **Step 78**.

Step 82

Install the nut.





Step 83

Tighten the nut using a 14 mm combination wrench until the nylon bushings begin to bulge.

Note: Make sure the bushings fit properly into the upper shock mount.



Step 84

Raise or lower the rear axle assembly with the floor jack (or under hoist jack stand) to align the lower shock mount with the lower shock absorber.



Step 85

Install the lower shock absorber mounting bolt.



Step 86

Install the lower shock absorber mounting nut.



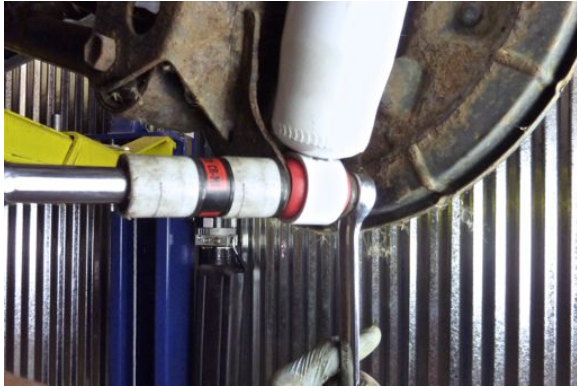

Step 87

While holding the nut with a 17 mm box end wrench, tighten the bolt using a 17 mm socket until the rubber bushing bulges.



Step 88

Reconnect the park brake cable bracket.

Step 89

Repeat **Steps 68 through 88** on the driver side rear wheel.



Step 90

Reinstall both rear wheels and torque the lug nuts. (55 ft. lbs.)



Step 91

Raise the vehicle, remove all jack stands, and lower the vehicle to the floor.

Congratulations:

You are done. Now stand back and admire your newly lifted vehicle. We here at Low Range applaud you. Thanks for letting us assist you. We hope this has been a positive experience. If you have suggestions on how we can improve our instructions please contact us and let us know your ideas. Our phone # is at the bottom of each page.

Caution:

Raising the ride height of a vehicle will adversely affect wheel alignment and headlamp aiming. We recommend you have both of these procedures performed by a qualified technician to insure your vehicle in safe operating condition. Failure to perform these adjustments, could result in excessive tire tread wear, improper braking, poor and unsafe vehicle handling and dangerous headlamp misalignment.



As always, If you experience any difficulty during the installation of this product please contact Low Range Off-Road Technical Support at 801-805-6644 M-F 8am-5pm MST. Thank you for purchasing from Low Range Off-Road.



These instructions are designed as a general installation guide. Installation of many Low Range Off-Road products require specialized skills such as metal fabrication, welding and mechanical trouble shooting. If you have any questions or are unsure about how to proceed, please contact our shop at 801-805-6644 or seek help from a competent fabricator. Using fabrication tools such as welders, torches and grinders can cause serious bodily harm and death. Please operate equipment carefully and observe proper safety procedures.

Rock crawling and off-road driving are inherently dangerous activities. Some modifications will adversely affect the on-road handling characteristics of your vehicle. All products sold by Low Range Off-Road are sold for off road use only. Any other use or application is the responsibility of the purchaser and/or user. Some modifications and installation of certain aftermarket parts may under certain circumstances void your original dealer warranty. Modification of your vehicle may create dangerous conditions, which could cause roll-overs resulting in serious bodily injury or death. Buyers and users of these products hereby expressly assume all risks associated with any such modifications and use.

Revised 02/13/13© Copyright 2013 Low Range Off-Road, LC All Rights Reserved

