

86-95 Suzuki Samurai Replacement Window Regulator (SKU# SIB-WR)

Also includes instructions for:

Door Glass Weather Stripping and Lower Scrapes (SKU#SEB-DWS)

Door Rubber "Super" Seal - Weather Stripping (SKU# SEB-DRS)

Installation Instructions



Door Glass
Weatherstripping



Door Seal-Weather
Stripping

CAUTION: Safety glasses should be worn at all times when working with vehicles and related tools and equipment.



Suggested Tools:

- Small Standard Screwdriver
- #2 Phillips Screwdriver
- #3 Phillips Screwdriver
- Slip Joint pliers
- Window Handle Removal Tool (or needle nose pliers)
- Door Trim Removal Tool





Step 1

Remove the inside handle case by removing (1) phillips screw.



Step 2

Remove the window handle.



This picture shows the clip that needs to be removed in order to remove the window handle.



Removal Method A

Window handle removal with handle removal tool.



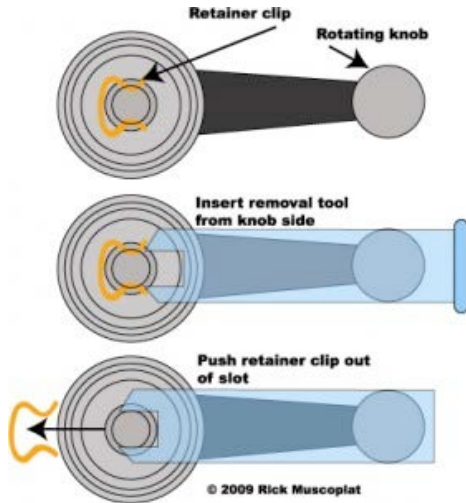

Removal Method A Illustrated



Removal Method B

Window handle removal with a rag.



Removal Method B Illustrated

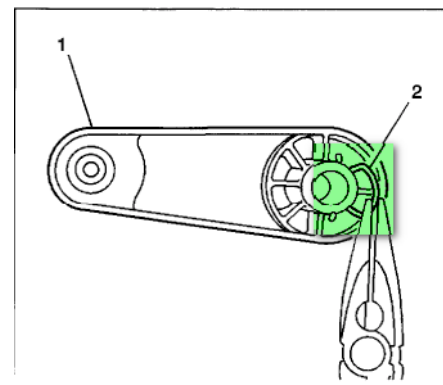

Removal Method C

Window handle clip removal with pliers (or hook).

A new Replacement Window Handle can be purchased on our website. Click [HERE](#) for more information.





Step 3

Remove the pull handle by removing (2) phillips screws.



Step 4

Remove the stopper band by removing (2) phillips screws.



Step 5

Separate the door panel from the door using a door trim tool.



Tech Tip A

Pop the fasteners loose by placing the tool behind the panel and prying gently at each fastener location. (See Tech Tip C on the next page for fastener locations)



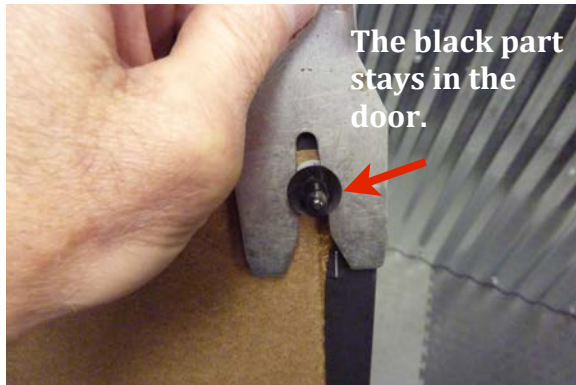

Tech Tip B

Showing proper tool positioning with door panel removed for a clearer view.

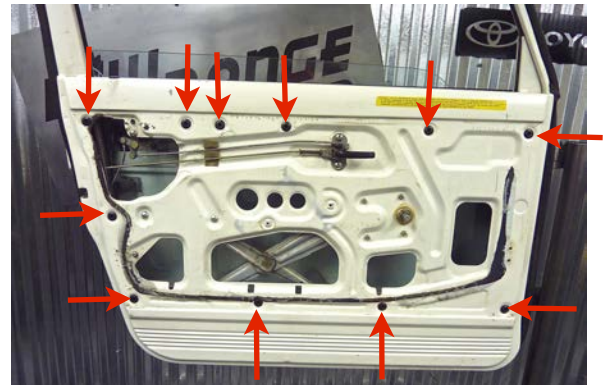

Tech Tip C

This picture shows the location of each of the (11) clips that need to be popped loose.



Step 6

Remove the door panel and set it aside.

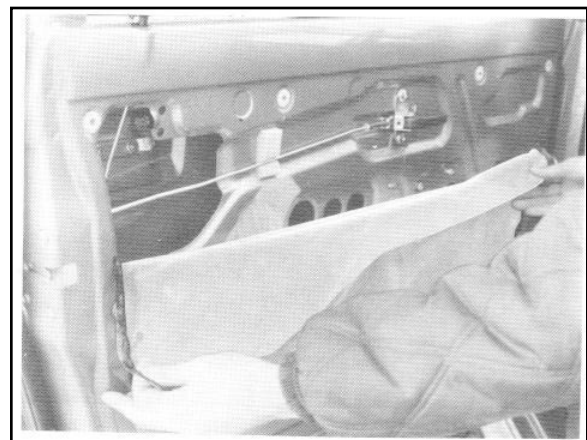

Step 7

Remove the waterproof film. If you are patient and careful the film and sealant can be reused.

Note: The Samurai door we worked on did not have this film in place. If the door you are working with still has this film, just peel it down, leaving the bottom of the film attached to the door.





Step 8

If installed, remove the clip from the window handle and temporarily install the handle back on the window regulator.

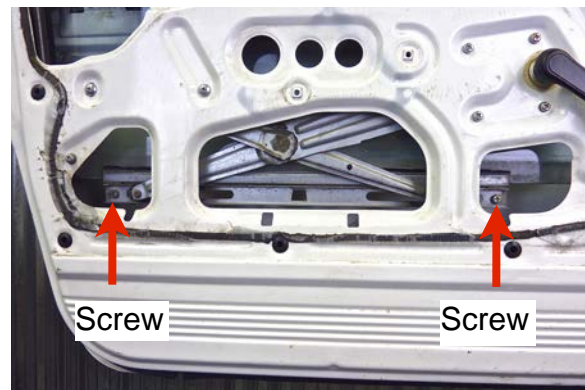

Step 9

Turn the handle, moving the window down, until the screws come into view as shown in the picture.

If you are not replacing the window scrapers and door seal, skip ahead to Step 19



Step 10

While holding the window, remove (2) phillips screws (shown in Step 9) using a #3 phillips screwdriver.

Extreme Caution: Be sure that you (or an assistant) holds the window while removing the screws as the window could drop and **BREAK**.

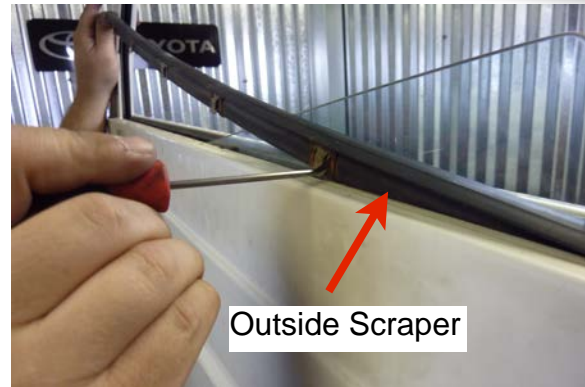

Step 11

Let the rear of the window drop down out of view as shown and remove the outside scraper by prying up with a pick or small screwdriver.

Caution: Be careful not to damage the paint on the door. It may be helpful to place a cloth between the tool and the painted door panel.





Step 12

Lift the window out on an angle as shown, and set it aside.



Step 13

Remove the inside scrapper using a pick or small screwdriver. Wedge the tool between the scrapper and the door as shown and pry gently.

Note: Again, be careful not to damage the paint.

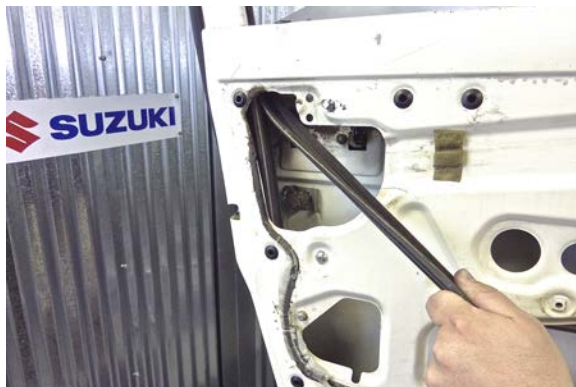

Step 14

Remove the window seal starting at the rear of the door and working toward the front of the door as shown.

Note: This seal is not glued in. It is held in place by the window itself. It should simply peel out with minimal effort.



Continuing the removal of the window seal.



Step 15

Ready the new seal by locating the lateral cut section of the new seal pictured above.

Note: Some seals do not have these lateral cuts. In these cases you will need to begin at one end of the seal, place it in the corresponding end of the channel and work your way back to the other end.



Step 16

Position this lateral cut section of the seal in the upper front corner of the window channel and press it firmly into place.



Step 17

Then press the rest of the seal into place around the window channel.

Note: The notch shown in the picture above goes to the rear corner of the window channel as shown. This notch may not be a characteristic of all door seals. If there is no notch, follow instructions given in the note in Step 15.



Step 18

Install the inside window scraper by aligning the clips with the holes in the door and snapping them into place.



Step 19

Turn the window handle so that the regulator is reduced to its smallest overall size.

Note: This is so the regulator can fit through the hole in the door as shown in step 21.

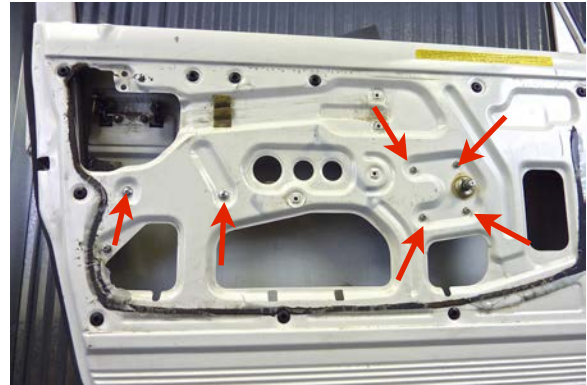

Step 20

Remove the window handle and detach the regulator from the door by removing (6) phillips screws.

Note: These screws can be tough to remove. If they are, an impact driver may be helpful. If you are not familiar with this tool, click [HERE](#) to see a video.

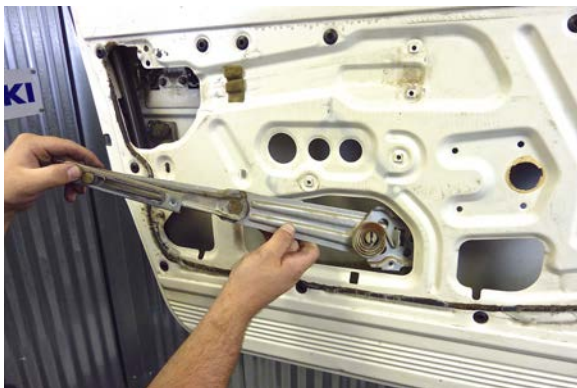

Step 21

Remove the old regulator from the door as shown.

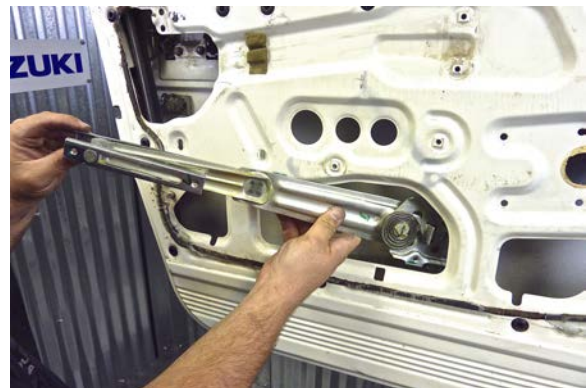

Step 22

Insert the new regulator into the door.





Step 23

Install (6) phillips screws but only tighten the 4 nearest the window handle area. Leave the other two loose for now.

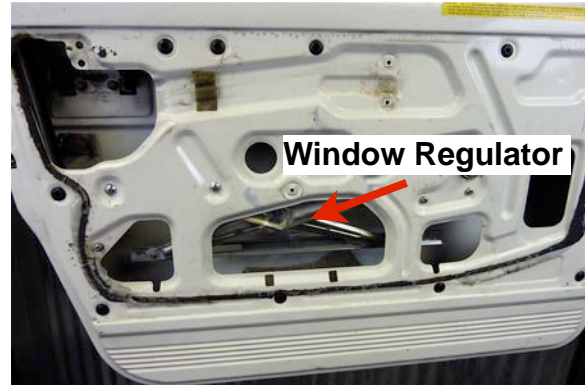

Step 24

Temporarily install the window handle and turn it until the the regulator is in the position shown.



Step 25

Install the window at an angle as shown.



Step 26

Install the (2) window-to-regulator screws and tighten.





Step 27

If the window is not all the way down, go ahead and roll it down.

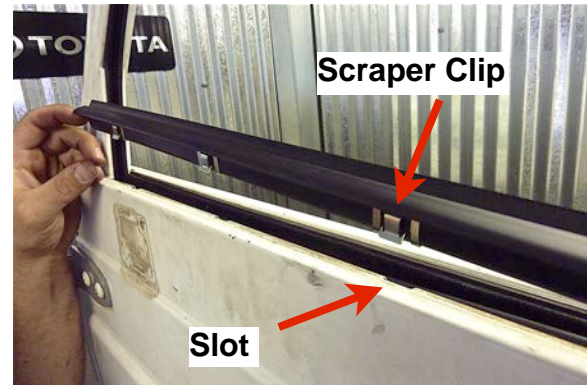

Step 28

Install the outside window scraper by aligning the clips with the slots and pressing firmly downward until all clips snap into place.



Step 29

Slowly roll the window all the way to the top by turning the window handle. If binding is felt at any point, slide the window forward or backward until binding is reduced to a minimum.

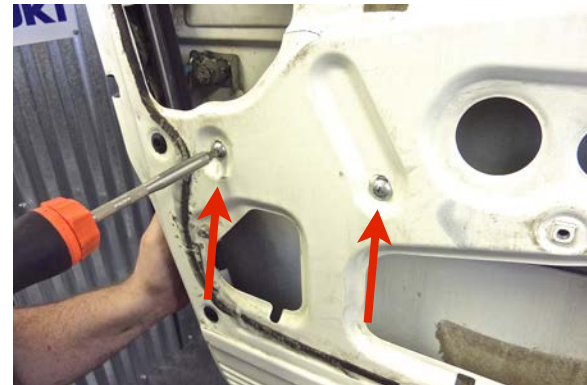

Step 30

Once the window is all the way to the top, tighten the two screws that were left loose in Step 23.





Step 31

Roll the window down and up to check for binding. If binding is felt, loosen the two screws just tightened and repeat steps 29 and 30 until the window works freely.

Note: It is normal for the window to be more difficult to roll up than down.



Step 32

Remove the window handle.

Step 33

Replace the waterproof film if removed earlier. If the film has minor damage it can be repaired with vinyl tape.



Step 34

Align the fasteners on the door panel with the holes in the door and press each one until it snaps.





Step 35

Install the pull handle.



Step 36

Install the handle case.



Step 37

Install the stopper band.



Step 38

Install the window handle clip on the window handle.





Tech Tip

Correct positioning of window handle clip.



Step 39

Install the window handle trim.



Step 40

Install the window handle.

Note: The window handle simply snaps into place with moderate pressure.

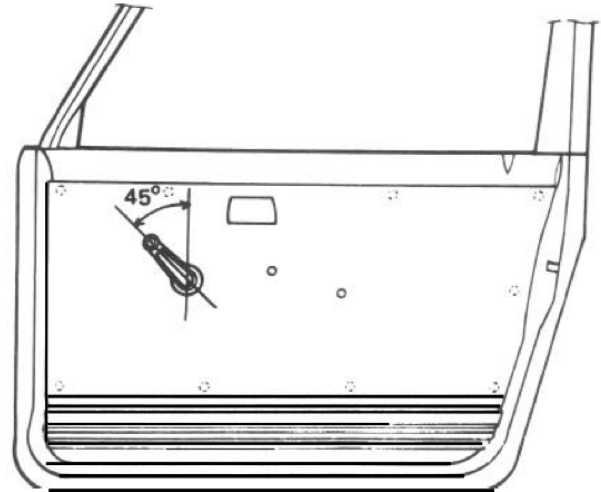

Tech Tip

When installing the handle it should be installed at 45° from true vertical, toward the front of the vehicle with the window rolled all the way up.



Step 41

Install the stopper band.

Congratulations!

You have successfully installed a window regulator and associated parts.

Continue on to **Step 42** if you are replacing the door weatherstrip/seal.

Door Weather Strip-Seal Replacement Instructions



Step 42

Begin by pulling the old weatherstrip away from the door. Some sections of the weatherstrip is held in place by clips and some a channel. When detaching the clip sections of the seal, the clip will most likely stay in the door.



Step 43

Remove all clips with slip joint pliers.



Step 44

To detach the section of the seal that is held in place by a channel simply pull the weather strip out of the channel.



Step 45

Begin installing the new weather strip at the upper rear corner of the door as shown.

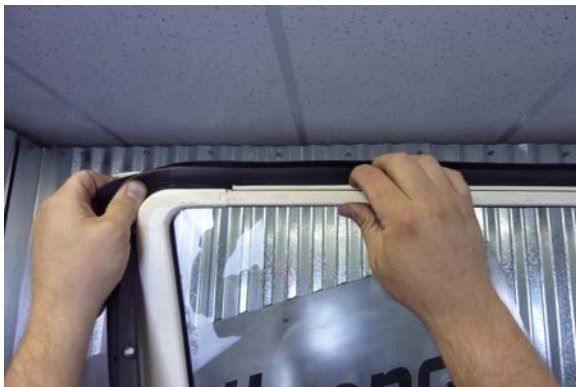

Step 46

Then work the weather strip into the channel along the top of the door.



Step 47

Continue working the weather strip into the channel along the front of the door.





Step 48

Continue installing the weatherstrip down the front and bottom of the door by inserting all the clips in the holes and pressing firmly until they snap. Continue until you reach the end of the seal at the bottom of the door.



Step 49

Then go back to the upper rear corner and attach the weatherstrip clips down the back of the door. Continue installing all the clips down the back of the door and along the bottom until all the clips are secure.

Job Completed!

Now enjoy your quieter more comfortable ride!

As always, If you experience any difficulty during the installation of this product please contact Low Range Off-Road Technical Support at 801-805-6644 M-F 8am-5pm MST. Thank you for purchasing from Low Range Off-Road.





These instructions are designed as a general installation guide. Installation of many Low Range Off-Road products require specialized skills such as metal fabrication, welding and mechanical trouble shooting. If you have any questions or are unsure about how to proceed, please contact our shop at 801-805-6644 or seek help from a competent fabricator. Using fabrication tools such as welders, torches and grinders can cause serious bodily harm and death. Please operate equipment carefully and observe proper safety procedures.

Rock crawling and off-road driving are inherently dangerous activities. Some modifications will adversely affect the on-road handling characteristics of your vehicle. All products sold by Low Range Off-Road are sold for off road use only. Any other use or application is the responsibility of the purchaser and/or user. Some modifications and installation of certain aftermarket parts may under certain circumstances void your original dealer warranty. Modification of your vehicle may create dangerous conditions, which could cause roll-overs resulting in serious bodily injury or death. Buyers and users of these products hereby expressly assume all risks associated with any such modifications and use.

Revised 06/21/12© Copyright 2012 Low Range Off-Road, LC All Rights Reserved

